

gForce Ultra



Single and Dual Circuit | 22 to 125 kW
Air/Water/Glycol Cooled



Model Number Identification

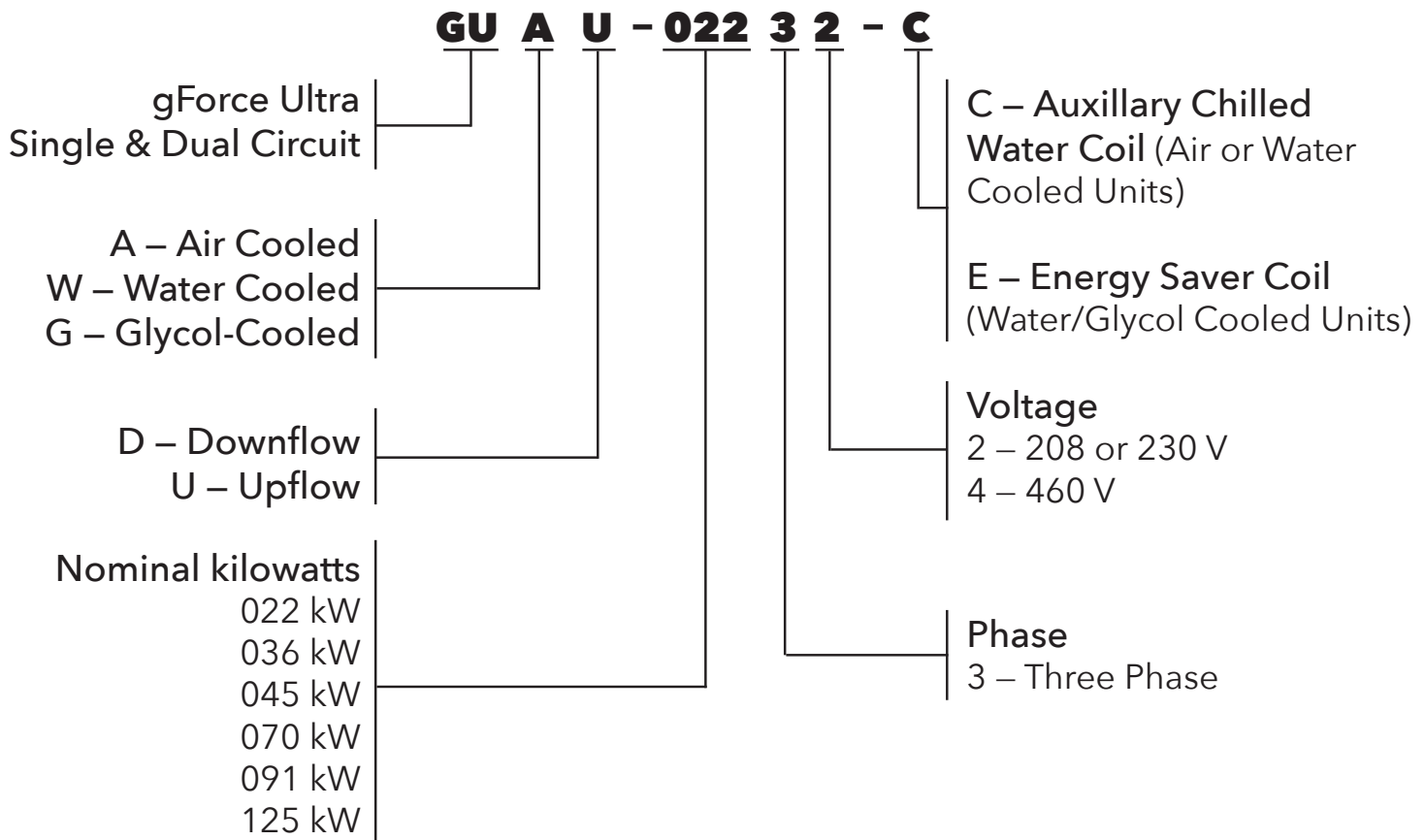



Building on more than 50 years of experience, Data Aire produces innovative solutions to meet the developing demands of critical spaces. We are a solutions-driven organization with a passion for finding creative answers by working with our customers through a consultative process.

Known for products that are designed utilizing high levels of technology, Data Aire engineers are experienced visionaries who adapt processes and design proprietary unit enhancements which reflect the constant needs of today's mission critical spaces.

Data Aire combines extensive expertise in control logic with world-class manufacturing capability recognized by key international quality certifications. For those seeking reliable, scalable, customized technology, we provide the solutions of choice. Our precision air control equipment and intelligent energy management technology serve customers in diverse applications worldwide.

Overview

Cooling data centers and other mission critical environments is an ever-changing challenge. Meeting this challenge while optimizing energy savings and dependability is the focus of Data Aire's recent product innovation. Data Aire is proud to introduce the latest in its line of gForce precision cooling units - gForce Ultra.

In addition to the impressive features found in Data Aire's gForce line, gForce Ultra also effectively manages fluctuating cooling demands, guarantees accurate cooling and achieves unsurpassed energy savings. All this is made possible by combining the advanced variable capacity technology with a Variable Frequency Drive Controller, Variable Speed Compressor, Electronic Expansion Valve and Venturi-Flo Refrigerant Distributor components.



Redefined Efficiency and Energy Savings

- Variable speed operation increases efficiency because when running at lower capacities, units use less energy and save money
- Achieves greater turndown while saving energy when compared to standard unit capacity measures. Turn down ratio is 4:1
- Slowly ramps up inrush to avoid surges

Increased Precision

- Variable capacity technology quickly adapts to required cooling demands and retains a precise set point
- Effectively manages humidity and regulates temperature to ensure protection of mission critical data and potentially extends the lifetime of your cooling equipment
- Precise operation and control of fluctuating loads

Scalability

- Customizable for flexible capacity ranges from 2 to 35 tons (7-125 kW), depending on the gForce Ultra model selected
- Units can scale up or down in capacity to meet demand
- Energy savings at part load by ramping down to the exact needed capacity and power needed to run at a given capacity

Design Features



More Control - (VFD)

An ultra-precise Variable Frequency Drive Controller (VFD) matches temperature set points almost perfectly, eliminating swings in temperature ranges - resulting in increased energy efficiency. It allows the compressor to hone in on the required load, meet that load and hold steady - only fluctuating capacity when the load increases or decreases.



Strict Regulation - (EEV)

An Electronic Expansion Valve (EEV) regulates the flow of refrigerant to the coil for maximum energy efficiency - allowing for superior superheat control and the ability to maintain a lower, energy-saving superheat.

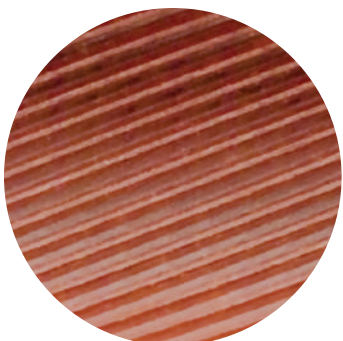

Optimized Coils

gForce Ultra's coils feature Rifled Tubing - yet another element that increases energy efficiency. Very similar to a bullet spinning down the bore of a rifle as it exits the barrel, the refrigerant in a gForce Ultra unit spins as it travels through the coil. This spinning forces the refrigerant against the inside surface of the coil - resulting in a higher heat transfer and therefore higher efficiency.

Pinpoint Temperatures - (VSC)

A Variable Speed Compressor (VSC) provides substantial variable capacity modulation to accurately match the varying temperature demands of an infrastructure. Instead of just simply turning on or off at preset temperatures, it adjusts and fluctuates as needed to help maintain a much tighter, optimal temperature range - often within one degree or less. This technology helps reduce power consumption, resulting in substantial energy savings.



Ultra-Efficient Flow - (VRD)

The Venturi-Flo Refrigerant Distributor (VRD) has an orifice designed to allow for maximum distribution efficiency with minimum pressure drop. The Venturi-style distributor equally dispenses refrigerant at half the pressure drop than fixed distributors.



The Right Fan

gForce Ultra's Backward-Curved Plenum Fans with electronically commutated (EC) motors operate without shafts, external bearings, belts or pulleys, which can break, slip and release dust - making them cleaner and more reliable than traditional fans - resulting in reduced maintenance and fewer premature fan and motor failures. Plenum fans also disperse air radially and at a lower speed, allowing for consistent static pressure and distribution of cool air closer to the unit to help maintain uniform room temperatures.



Intelligent Controls

SMART SYSTEM CONTROLS FOR MISSION CRITICAL ENVIRONMENTS

Incorporating advances based on years of control-logic experience, Data Aire system control products offer maximum operational flexibility and growth potential. From a versatile microprocessor controller or a dependable relay autochangeover unit, to accessories that help prevent hot spots in rack installations and compensate for short-term power outages, Data Aire technology keeps you in command.

The Mini-Ceiling systems come equipped with Mini dap4 touch for the dap4 control panel. Mini dap4 supports the following network protocols for integration with a Building Management System (BMS) for Computer Room Air Conditioning (CRAC) system monitoring and control: Modbus RTU, TCP/IP, SNMP V1 or V2, BACnet IP or MS/TP and LonTalk SNVT. Building Management System Interface: Unit(s) shall be furnished with an optional interface card to communicate directly with the Building Automation System (BAS) through a RS-485, Ethernet or LonTalk port. All alarms, set points, and operating parameters that are accessible from the unit mounted control panel shall also be made available through the BAS.

CONTROLS

AUTOMATIC CONTROL FUNCTIONS

- Humidity Anticipation
- Auxiliary Chilled Water Operation*
- Sequential Load Activation
- Start Time Delay
- Automatic Reheat Element Rotation
- Temperature Anticipation
- Energy Saver (Glycol Operation)*
- Hot Water Coil Flush Cycle*
- Dehumidification Lockout
- Chilled Water Coil Flush Cycle*
- Energy Saver Coil Flush Cycle*
- Selectable Water Under Floor Alarm Action
- Compressor Short Cycle

CONDITION AND DATA ROUTINELY DISPLAYED

- Current Date and Time
- Unit Status
- Temperature Setpoint
- Humidity Setpoint
- Current Temperature
- Cooling 1, 2, 3, 4*
- Current Humidity
- Dehumidification
- Humidification
- Current Fan Speed*
- Reheat Stages
- Discharge Temperature*

SWITCHING AND CONTROL FUNCTIONS

- System On/Off/Esc Button
- Menu Selection Buttons
- Menu Exit Button
- Select Buttons
- Alarm Silence Button
- Program Set Button
- Manual Override for:
 - Cool 1, Cool 2, Heat 1,
 - Humidification, CW Valve
 - and Fan Speed

ALARMS

- High Temperature Warning
- Low Temperature Warning
- Low Pressure Compressor 1
- High Pressure Compressor 1
- Dirty Filter
- Firestat Tripped
- Temperature Sensor Error
- No Water Flow*
- Fan Motor Overload*

- High Humidity Warning
- Low Humidity Warning
- Low Pressure Compressor 2
- High Pressure Compressor 2
- Under Floor Water Detection
- Compressor Short Cycle
- Humidity Sensor Error
- Smoke Detector*
- Standby Pump On*

- Local Alarm
- Manual Override
- Humidifier Problem
- Custom Message*
- Power Failure Restart
- Maintenance Required
- Discharge Sensor Error*
- High Condensate Water Level*
- Person to Contact on Alarm*

HISTORICAL DATA

High Temperature Last 24 Hours
High Humidity Last 24 Hours
Alarm History (Last 100 Alarms)
Equipment Runtimes for:
Blower, Compressor 1, Compressor 2, Reheat 1, 2, 3, Dehumidification,
Energy Saver*, Humidifier, Condenser and Chilled Water

Low Temperature Last 24 Hours
Low Humidity Last 24 Hours
Hourly Average of Duty

PROGRAMMABLE FUNCTIONS

Temperature Setpoint	Temperature Deadband	Fan Control Mode
System Start Delay	Low Temperature Alarm Limit	Humidity Deadband
Humidity Setpoint	High Humidity Alarm Limit	Low Humidity Alarm Limit
Define Password	Reset Equipment Runtimes	Audio Alarm Mode
Compressor Short Cycle Alarm	Humidity Anticipation	Compressors(s)
Analog Module Sensor Setup*	Calibrate Temperature Sensor	Temperature Scale
High Temperature Alarm Limit	Fan Speed Settings	Delay for Optional Alarm 1, 2, 3, 4
Firestat Temperature Alarm Limit	Manual Diagnosis	Remote Alarm 1, 2, 3, 4 Selection
Calibrate Discharge Air Sensor*	Person to contact on Alarm	Compressor Lead/Lag Sequence
Dehumidification Mode	Humidifier Autoflush Timer*	Power Problem or Restart Mode
Scheduled Normal Maintenance	Reheat Stages	Water Valve Mode
Calibrate Humidity	Humidifier	Network Protocol
Compressor Supplements to Energy Saver*		
Low Discharge Temperature Alarm Limit*		
Calibrate Chilled Water Temperature Sensor*		

ACCESSORIES

RackSense 32
dap4 Smart Power Capacitor
dap4 Power Meter

* Optional: Some of the programmable selections, displays or alarms may require additional components or sensors.

Models & Capacities

GUXX-070XX @ 8000 CFM (Dual Circuit)							
EAT (DB/WB)	Air Cooled		Glycol Cooled		Water Cooled		Capacity Range*
	Net Total BTU/hr	Net Sensible BTU/hr	Net Total BTU/hr	Net Sensible BTU/hr	Net Total BTU/hr	Net Sensible BTU/hr	Tons (kW)
72/58.6	205,717	173,612	198,533	170,217	225,002	182,871	4-19 (13-70)
72/60	211,631	163,197	204,283	159,811	231,272	172,392	
75/61	215,738	177,255	208,284	173,882	235,656	186,416	
75/62.5	222,340	166,063	214,812	162,749	242,750	175,191	
80/67	242,787	167,957	234,694	164,694	264,723	176,954	
85/64.5	230,667	221,712	222,838	218,382	251,677	230,798	

GUXX-091XX @ 10000 CFM (Dual Circuit)							
EAT (DB/WB)	Air Cooled		Glycol Cooled		Water Cooled		Capacity Range*
	Net Total BTU/hr	Net Sensible BTU/hr	Net Total BTU/hr	Net Sensible BTU/hr	Net Total BTU/hr	Net Sensible BTU/hr	Tons (kW)
72/60	279,198	220,413	269,505	215,968	305,181	232,515	5-27 (18-95)
75/61	284,505	239,211	274,660	234,776	310,989	251,323	
75/62.5	293,151	224,283	282,966	219,825	320,348	236,383	
80/62.9	294,905	267,731	284,707	263,287	322,148	279,782	
80/67	319,842	226,917	308,951	222,544	348,931	238,784	
85/64.5	303,723	298,545	294,584	294,584	331,648	310,554	

GUXX-125XX @ 14000 CFM (Dual Circuit)							
EAT (DB/WB)	Air Cooled		Glycol Cooled		Water Cooled		Capacity Range*
	Net Total BTU/hr	Net Sensible BTU/hr	Net Total BTU/hr	Net Sensible BTU/hr	Net Total BTU/hr	Net Sensible BTU/hr	Tons (kW)
72/60	360,608	285,672	340,936	276,662	411,293	309,489	6-35 (20-125)
75/61	369,031	311,848	347,840	302,295	419,290	335,050	
75/62.5	383,005	292,701	362,651	283,767	429,230	318,679	
80/62.9	382,496	350,434	367,001	343,716	434,479	373,640	
80/67	422,885	298,052	401,388	289,372	471,865	318,220	
85/64.5	396,721	393,420	395,920	395,920	447,769	415,567	

*Averages based on Entering Air Temperatures of 75/61 across entire product line all cooling configurations

GUXX-022XX @ 2500 CFM (Single Circuit)							
Entering Air Temp DB/WB	Air Cooled		Glycol Cooled		Water Cooled		Capacity Range*
	Net Total BTUh	Net Sensible BTUh	Net Total BTUh	Net Sensible BTUh	Net Total BTUh	Net Sensible BTUh	Tons (kW)
72/60	69,782	55,406	67,829	54,511	75,367	57,997	2-6 (7-22)
75/61	71,147	59,775	69,032	58,824	76,688	62,301	
75/62.5	73,124	56,330	70,959	55,383	78,797	58,845	
80/62.9	73,582	66,328	71,424	65,392	79,277	68,837	
80/67	79,251	56,886	76,950	55,966	85,246	59,321	
85/64.5	75,542	73,375	73,338	72,441	81,330	75,855	
90/66.2	79,511	79,511	77,711	77,711	83,817	82,597	
95/67.8	83,605	83,605	81,775	81,775	88,361	88,361	
100/69.3	87,766	87,766	85,904	85,904	92,613	92,613	
100/70.8	87,766	87,766	85,904	85,904	92,613	92,613	

GUXX-036XX @ 5000 CFM (Single Circuit)							
Entering Air Temp DB/WB	Air Cooled		Glycol Cooled		Water Cooled		Capacity Range*
	Net Total BTUh	Net Sensible BTUh	Net Total BTUh	Net Sensible BTUh	Net Total BTUh	Net Sensible BTUh	Tons (kW)
72/58.6	139,007	113,427	134,318	111,319	151,385	119,079	6-11 (20-40)
72/60	141,468	122,567	136,721	120,472	154,058	128,210	
75/61	145,424	115,272	140,560	113,187	158,319	120,891	
75/62.5	146,241	136,425	141,375	134,353	159,201	142,031	
80/67	157,732	116,518	152,527	114,474	171,591	122,046	
85/64.5	151,638	151,638	147,632	147,632	163,537	156,997	
90/66.2	159,943	159,943	155,829	155,829	170,750	170,750	
95/67.8	168,397	168,397	164,143	164,143	179,449	179,449	
100/69.3	176,960	176,960	172,638	172,638	188,284	188,284	
100/70.8	176,960	176,960	172,638	172,638	188,284	188,284	

GUXX-045XX @ 5500 CFM (Single Circuit)							
Entering Air Temp DB/WB	Air Cooled		Glycol Cooled		Water Cooled		Capacity Range*
	Net Total BTUh	Net Sensible BTUh	Net Total BTUh	Net Sensible BTUh	Net Total BTUh	Net Sensible BTUh	Tons (kW)
72/58.6	155,710	127,752	147,463	124,066	182,903	140,255	7-15 (24-53)
72/60	158,617	138,174	150,264	134,508	189,612	152,209	
75/61	167,383	131,770	165,970	165,970	197,538	145,117	
75/62.5	170,443	156,644	175,530	175,530	195,955	167,850	
80/67	208,756	150,570	206,236	149,558	219,545	149,362	
85/64.5	179,334	157,154	208,914	198,848	203,951	185,929	
90/66.2	200,383	200,383	195,326	195,326	211,515	202,666	
95/67.8	210,595	210,595	205,415	205,415	224,195	224,195	
100/69.3	220,992	220,992	215,695	215,695	234,866	234,866	
100/70.8	220,992	220,992	215,695	215,695	234,866	234,866	



www.DataAire.com
800-347-2473 | sales@DataAire.com
230 W. Bueridge Avenue
Orange, CA 92865



A member of the
C/S Group of Companies
Making Building Better®